

Chip Ferrite Bead High Current Type Size 0402

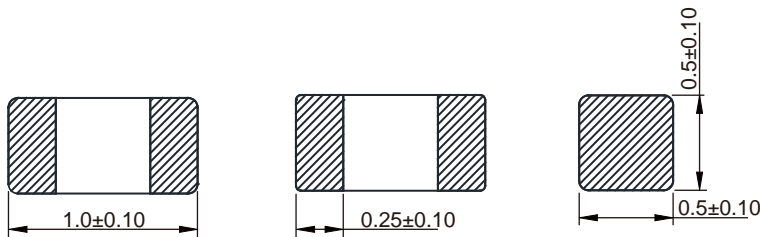

- Noise reduction solution for power line.
 - Compared to the FBA series, has low direct current resistance for compatibility with large currents, optimal for low power consumption. Various frequency characteristics with 2 materials of different features for countermeasures against everything from general signals to high-speed signals.
 - Performs well even in signal lines where low direct current resistance is required.
 - AEC-Q200 qualified.
 - Operating temperature: -55 to +150 °C (including self-temperature rise)
 - Quantity: 10000PCS
-
- Power line filter for body controls, and car multimedia etc.

Dimensions: [mm]



Land Pattern: [mm]

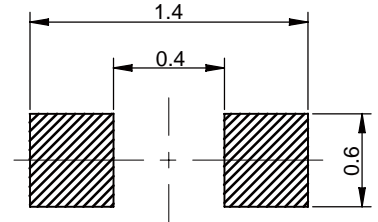

Electrical Properties:

Part No	Impedance @ 100MHz (Ω)	Tolerance	DC Resistance Max. (Ω)	Rated Current Max. (mA)
FBHA0402-100-202R	10	±25%	0.100	2000
FBHA0402-100-252R	10	±25%	0.050	2500
FBHA0402-330-302R	33	±25%	0.022	3000
FBHA0402-600-252R	60	±25%	0.032	2500
FBHA0402-800-232R	80	±25%	0.038	2300
FBHA0402-121-202R	120	±25%	0.095	2000
FBHA0402-221-152R	220	±25%	0.150	1500

I_R referring to 40K self-heating above ambient temperature

Typical Electrical Characteristics:

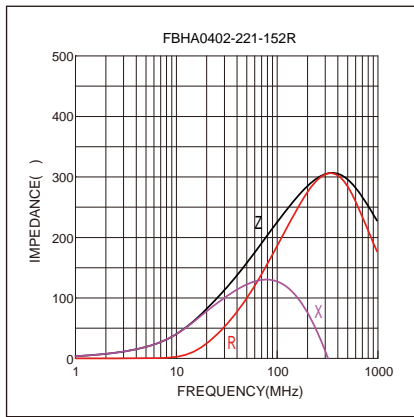
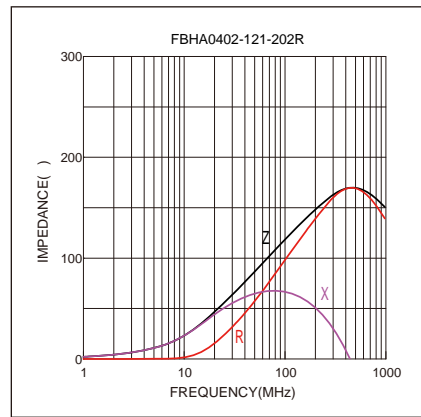
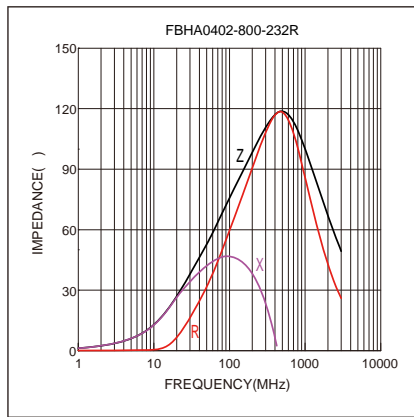
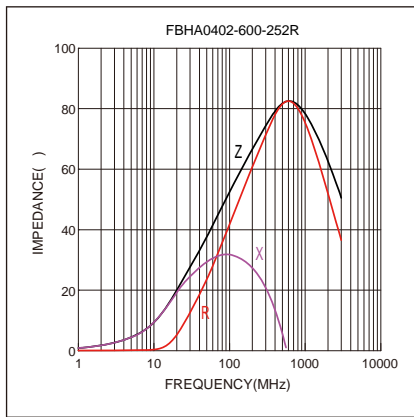
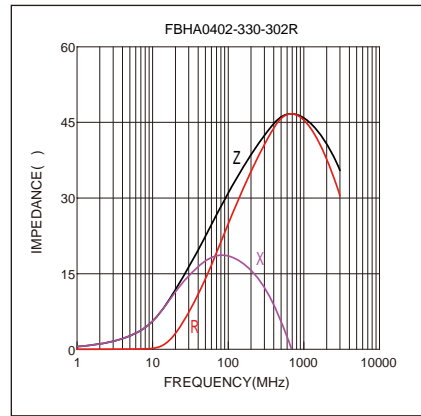
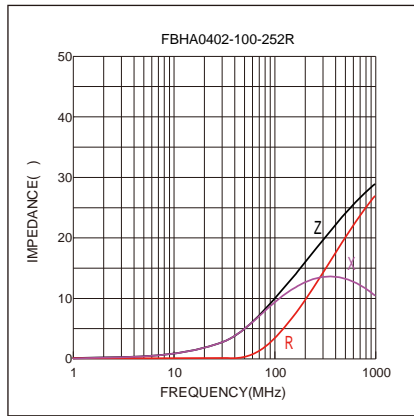
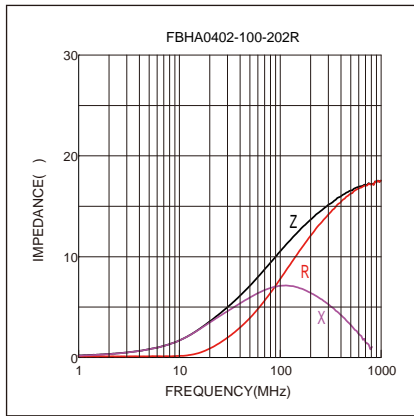

Soldering Reflow:

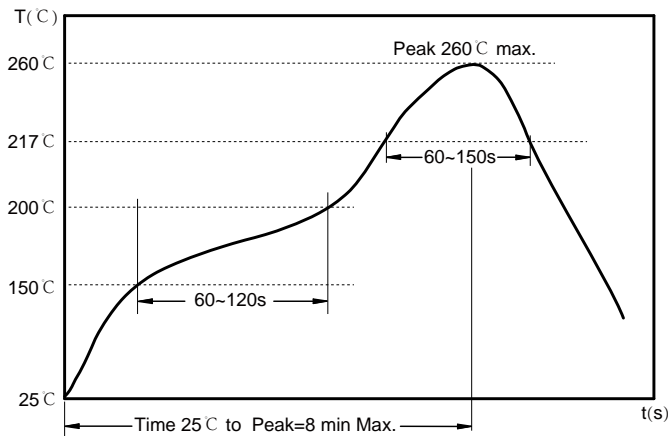

Preheat condition: 150 ~200 °C / 60~120 sec.

Allowed time above 217 °C : 60~150 sec.

Max temperature: 260 °C .

Allowed Reflow time: 3x max.

Packaging Information:

Tape Dimension:

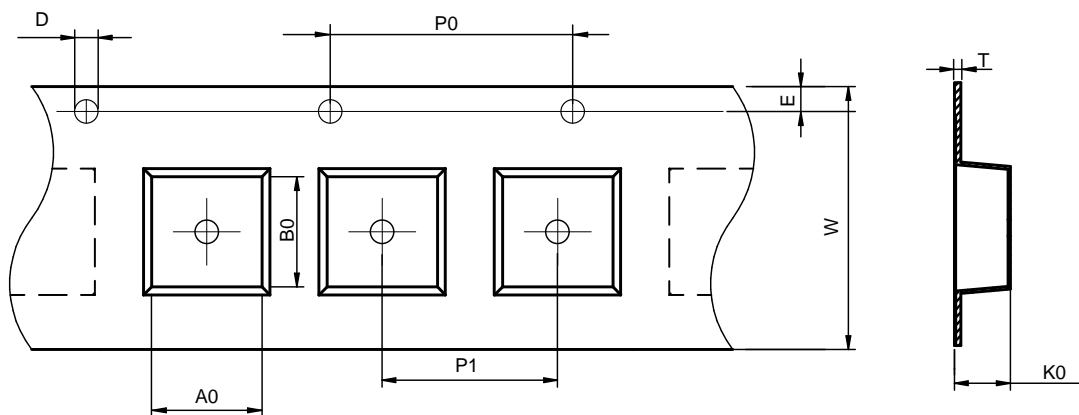

Series	A0 (mm)	B0 (mm)	D (mm)	P0 (mm)	P1 (mm)	W (mm)	K0 (mm)	E (mm)	T (mm)
FBHA0402	0.62± 0.03	1.12± 0.03	1.5± 0.1	4.0± 0.1	2.0± 0.05	8.0± 0.3	0.60± 0.03	1.75± 0.1	0.60± 0.03

Peel force of top cover tape:

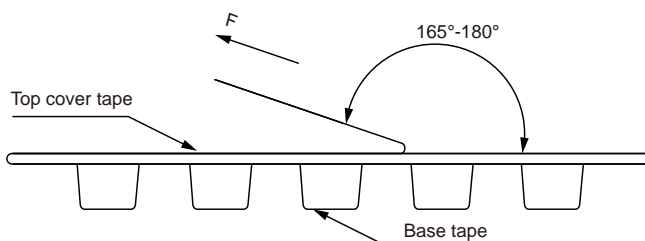

The peel force of top cover tape shall be between 0.14 to 0.58 N

Reel Dimension: [mm]

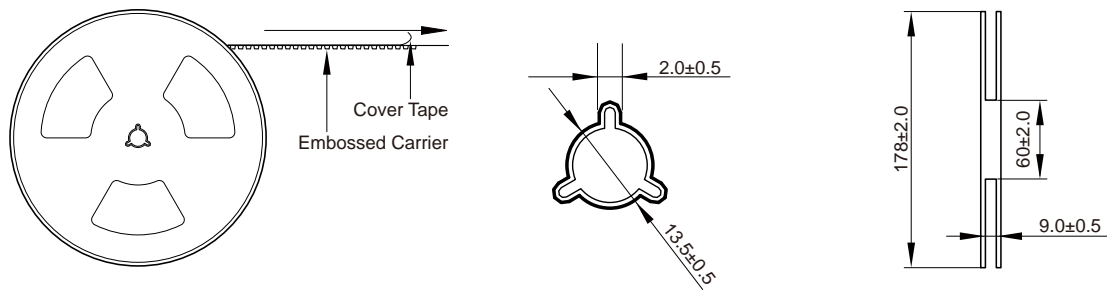

Packaging Quantity:

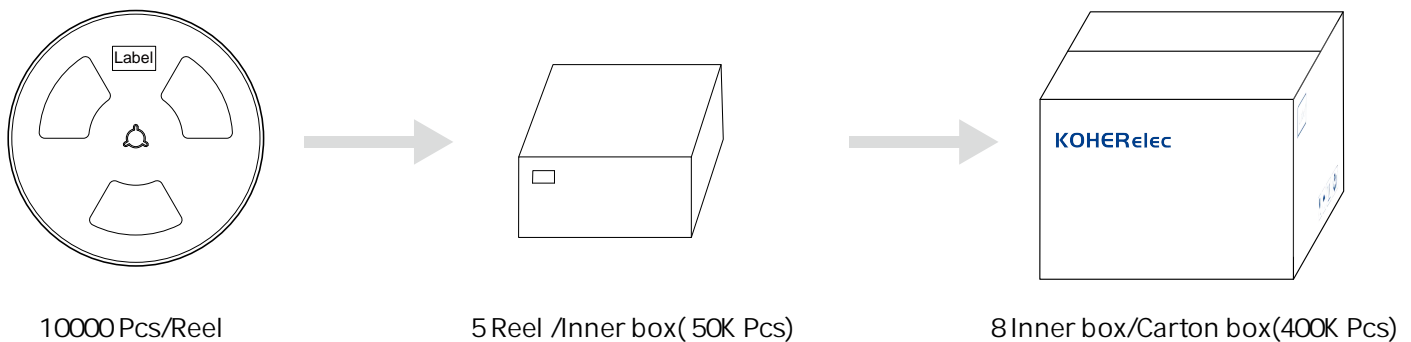

Cautions and Warnings:

Storage Conditions :

- The storage period is within 12 months after the completion of production. Be sure to follow the storage conditions (temperature: -5 to 35°C, humidity: 75% RH Max).If the storage period elapses, the soldering of the terminal electrodes may deteriorate.The warranty period is one year.
- Product should not be exposed to environment with high temperature, high humidity, dust, corrosive gas and etc.
- Products should be handled with care to avoid damage or contamination from perspiration and skin oils.
- Please always handle products carefully to prevent any damage caused by dropping down or inappropriate removing.

Operation Instructions:

- Self heating (temperature increase) occurs when the power is turned ON, so the tolerance should be sufficient for the set thermal design.
- Before soldering, be sure to preheat components.The preheating temperature should be set so that the temperature difference between the solder temperature and chip temperature does not exceed 150°C.
- Soldering corrections after mounting should be within the range of the conditions determined in the specifications.If overheated, a short circuit, performance deterioration, or lifespan shortening may occur.
- Generally, Koher might not be familiar with either customer's specific application or actual requests as customer does.As a result customer shall be responsible for checking and confirming whether Koher product with the performance described in the product specification is suitable for using in customer's particular application or not.